

Operating Manuel

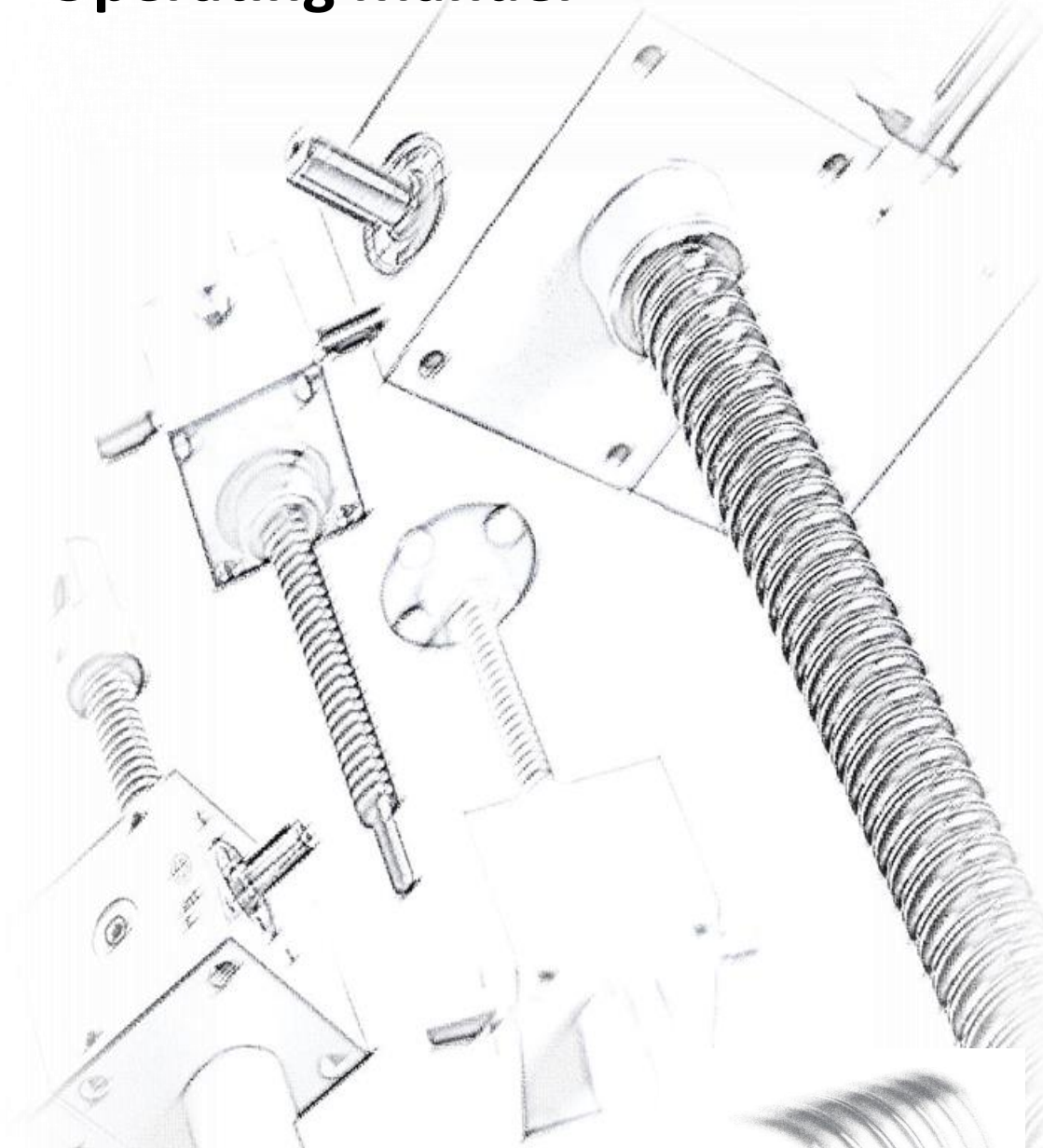

NEFF-High Speed Screw Jacks G1-G3
Version N/V/R

NEFF
GEWINDETRIEBE

Contents

1	Important Information	2
1.1	Instructions on Documentation	2
1.2	Safekeeping of the Documentation	2
1.3	Used Symbols	2
1.4	Qualified Staff	2
1.5	General Safety Instructions.....	3
2	Overview of the High Speed Screw Jacks	4
3	Setup High Speed Screw Jack	5
3.1	Version R, rotating spindle.....	5
3.2	Version N/VK, lifting spindle	5
4	Assembly	6
4.1	General Assembly Instructions	6
4.2	Assembly guide	7
4.3	Tolerance of position	7
4.4	Mounting Several High Speed Screw Jacks in Parallel	8
4.5	Disassembly the Screw.....	9
5	Commissioning	10
6	Maintenance	10
6.1	Lubricants and Fill Quantities.....	11
7	Malfunctions	12
8	Manufacturer’s Declaration	13

1 Important Information

This chapter contains important information on the safe handling of the product and on this operating manual.

1.1 Instructions on Documentation

The following instructions will guide you through the entire documentation. We assume no liability for damages resulting from non-compliance with this operating manual. Forward this operating manual to the plant operator so that it is available if needed.

1.2 Safekeeping of the Documentation

Keep this operating manual and all other applicable documents safe so that they are available if needed.

1.3 Used Symbols



Information

Instructions and information on the operation of the High Speed Screw Jacks.



Attention!

Non-compliance may result in material damage and impair the operation of the gear unit.



Warning!

Safety instruction: non-compliance may result in serious or fatal injuries.



QR Barcode

Provides a direct link to the products on our website. Compatible with QR barcode scanner apps for all Android, Apple and Windows smart phones / tablets.

1.4 Qualified Staff



Qualified staff according to this operating manual refers to specialists who are familiar with the installation, assembly, commissioning and operation of the High Speed Screw Jacks and the hazards involved and who possess the necessary capabilities on the basis of their specialist training and knowledge of the applicable standards.

1.5 General Safety Instructions

The following warnings, preventive measures and instructions are intended to guarantee your safety and to avoid damage to the lifting gear or the components connected to it. This chapter contains warnings and instructions that generally apply to the handling of the lifting gear.



Intended Use:

The G1-G3 High Speed Screw Jacks are intended only to carry out lifting, lowering, tilting and feeding motions.

Please find lifting capacities in our catalog or at www.neff-gewindetriebe.de.

Any other use is considered misuse. The manufacturer assumes no liability for any damage resulting from misuse.

If the device is installed in machines or plants, commissioning is prohibited until it is determined that it complies with the EC machinery directive.



Attention!

Requirement according to the German accident prevention regulations VBG14 / VBG 70:

If High Speed Screw Jacks are operated in theatre stages (VBG 70), lifting platforms (VBG 14) or lifting equipment where there is a danger to persons, we generally recommend using a safety nut for fall protection.



Attention!

This operating manual must be kept close to the device and be easily accessible and available to all users.



Attention!

Risk of damage to the lifting gear resulting from storage and transport.

Correct storage, installation and assembly as well as diligent operation and maintenance are prerequisites for the trouble-free and safe operation of the High Speed Screw Jacks.

The High Speed Screw Jacks must be protected against mechanical impacts and vibrations during transport and storage.



Warning!

Work on live components:

E.g. installation of limit switches or a drive unit must only be carried out by trained electricians.

2 Overview of the High Speed Screw Jacks



Description of a High Speed Screw Jacks:

Neff High Speed Screw Jacks are used for applications where precise lifting, lowering, tilting and feeding motions are required. Our standard range comprises 3 models (G1-G3). The cubic housing that is machined on 4 sides allows for the installation of motors, gears or pressure transducers. All models are designed to cater for pressure and tensile loads as well as position-independent operation.

Basically, 2 different movement principles have to be distinguished:

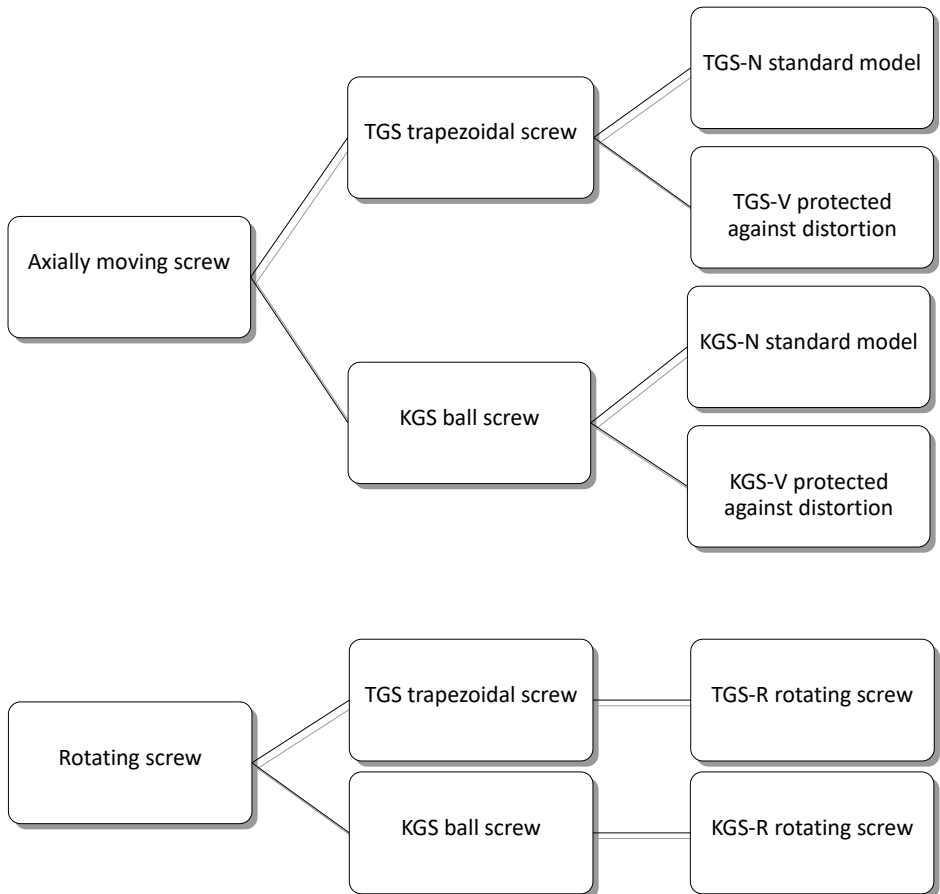

3 Setup High Speed Screw Jack

3.1 Version R, rotating spindle

Neff-High Speed Screw Jacks Version R with rotating spindle are equipped with spiral-toothed bevel gear, gear oil lubrication and greased spindle .

For Bevel gear Position RU:

By turning the drive shaft with right rotation, the bevel gear wheel and the spindle is driven right.

For Bevel gear Position RO:

By turning the drive shaft with right rotation, the bevel gear wheel and the spindle is driven left.

The bevel gear is seated on a hollow shaft which is attached via a feather key with the spindle.

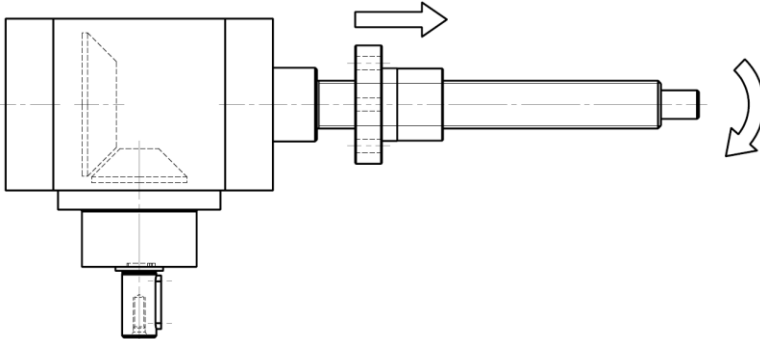

3.2 Version N/VK, lifting spindle

Neff High Speed Screw Jacks Version N/VK with lifting spindle are equipped with spiral-toothed bevel gear, gear oil lubrication and greased spindle .

For Bevel gear Position RU: (Bevel gear wheel above from the spindle side)

By turning the drive shaft with right rotation, the bevel gear wheel and the spindle is lifting up.

For Bevel gear Position RO: (Bevel gear wheel below from the spindle side)

By turning the drive shaft with right rotation, the bevel gear wheel and the spindle is lifting down.

The bevel gear is seated on a hollow shaft with integrated trapezoidal or ball nut.

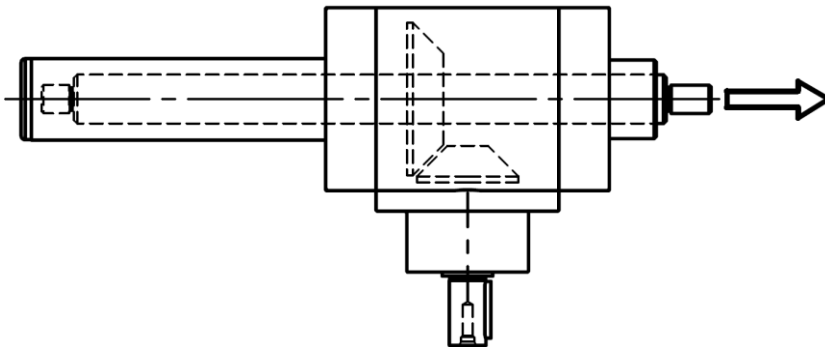

4 Assembly

4.1 General Assembly Instructions



The High Speed Screw Jack is fastened via the housing or other fastening components (mounting plates or cardan adapters, see QR code below). The housing always needs to be screwed to a machined surface (not to rolled steel profiles or similar) in order to avoid misalignment or noise.

Depending on the respective application, the High Speed Screw Jack and the screw have to be precisely aligned at a right angle or in parallel to the machine component and tightened during assembly.

The tolerances of the four assembly sides correspond to the DIN ISO 2768-mH standard.

Size	G1	G2	G3
Bolts (min. 8.8)	M10	M12	M20
Length of engagement	15	16	30
Max. torque in Nm	50	80	400

The torques mentioned in the table are only rough and nonbinding guidelines – see VDI 2230.



Lateral forces have to be absorbed by suitable guiderails; otherwise the device lifecycle would be shortened.



Attention!

The lubrication nipples must always be accessible during operation.



Attention!

Do not hammer the shaft end or the screw when aligning the High Speed Screw Jack.

QR barcode to Neff fastenings:



QR barcode to Neff attachments:



4.2 Assembly guide



1. Ensure parallelism between spindle and machine guides
2. adjustments, always start continued from the basic position, with the lowest clearance between gear and guided along the entire stroke length.
3. Avoid stress!. (Important for the life time)
4. The drive shaft must be easy and possible to turn evenly over the entire stroke length.
5. For trapezoidal spindle: Clean and lubricate the spindle over the entire stroke length
6. For ball screws: Clean the spindle over the entire stroke length and lubricate the ball nut.
7. Check the oil level in the gear box.
8. Replace the oil screw plug with the vent valve, thereby making sure that the vent valve is freely accessible.

4.3 Tolerance of position

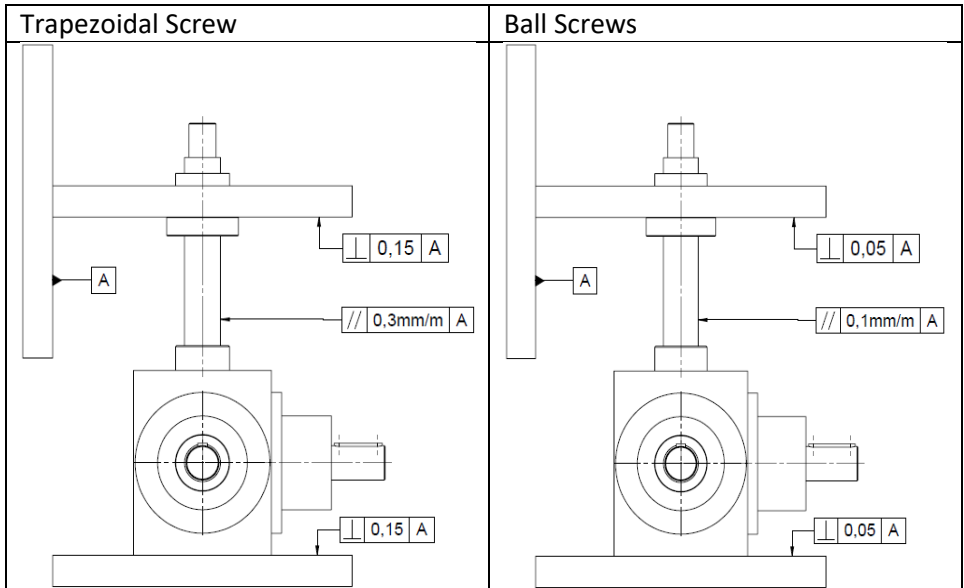

Tolerance of position is valid for all version (N/V/R)

4.4 Mounting Several High Speed Screw Jacks in Parallel

Requirement:

One High Speed Screw Jack is already installed and fastened as described in chapter 4.



9. Bring the second High Speed Screw Jack into the planned position, but do not fasten it yet.
 10. If rotating screws are used, bring the travelling nuts into the same position.
 11. Push the coupling or drive shaft onto the bevel gear shaft of the High Speed Screw Jack that is already fastened.
 12. Push the coupling or drive shaft onto the bevel gear shaft of the second High Speed Screw Jack.
 13. Fasten the High Speed Screw Jack.
 14. Repeat steps 1-5 with any other gear units.
-

**Attention!**

Check the sense of rotation of all lifting elements before assembly.

**Attention!**

Use torsionally flexible couplings, drive shafts or cardan shafts in order to compensate for any misalignment of the High Speed Screw Jacks.

**Attention!**

Observe the lubricating film and screw temperature during run-in. If the screw quickly runs dry (or if there are loud running noises with ball screws) and if the temperature is increased despite observing duty time and permissible power, this indicates impermissible lateral forces.

QR barcode to Neff couplings:



QR barcode to Neff drive shafts:



4.5 Disassembly the Screw

Version R, rotating spindle:

- Loosening the cap (2) from the bearing neck with a sharp screw driver. (1)
- Loosen the threaded screw (3) from the spindle mounting nut. (4)
- Remove the spindle mounting nut(4) with a face spanner.
- Pull the spindle (5) out of the housing.

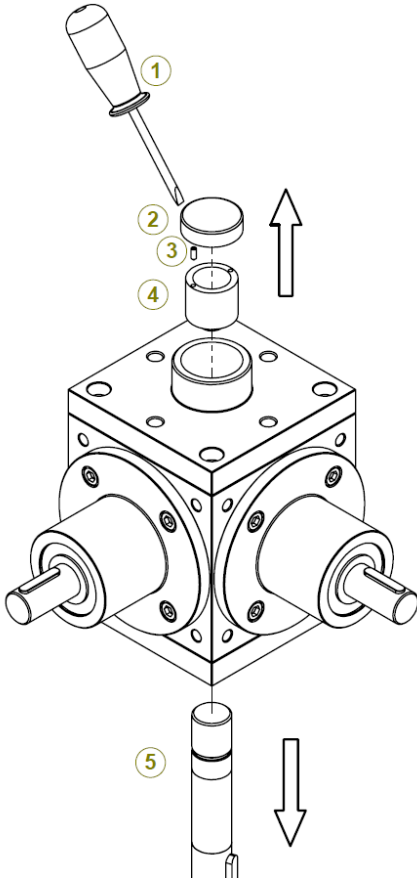

Version N/V, lifting spindle:

- Loosen the spindle mounting.
- Loosen the gard tube from the gear housing.
- Unscrew the spindle out of the gear housing.

5 Commissioning



Attention!

Screw Jack oil filled and with vent valve: Install enclosed vent valve before operation.
Note install position, vent valve must be mounted above the oil level.



Attention!

Check the operation of the limit switch. If possible, start the High Speed Screw Jack without any load and increase the load slowly.
During commissioning, continuously check the operating temperature, power consumption of the motor and the screw contact pattern.

6 Maintenance



- **With trapezoidal screws, regularly** lubricate the screw.
 - **With ball screws, observe the following guideline:** lubricate approx. every 200 hours with 1ml per 10mm of screw diameter
 - **For version VK:** The anti rotating block must be regularly lubricated. Move the Screw Jack to the start position, carefully dismount the square pipe plug and lubricate through the recesses in the anti rotating block. Prevent dry running! Recommendation for the interval: check once a month and if necessary relubricate (depending on application)
 - **Approx. 5 operating hours** after commissioning: Retighten all attachment bolts.
 - **After approx. 50-100 operating hours:** Lubricate the gear at the lubrication nipples once again.
 - **After approx. 200 operating hours or 1 year** (sooner in tough operating conditions):
Check the screw nut for signs of wear and tear.
Clean the screw of old grease and relubricate.
 - **After approx. 1000 operating hours or 5 years:** Disassemble gear, clean it of old oil and relubricate:
-



Attention!

For mounting new oil screw plugs: Take new seals!



Attention!

Change the screw nut if the axial play exceeds 1/4 of the thread pitch (trapezoidal thread).

6.1 Lubricants and Fill Quantities



Types of factory grease:

High Speed Screw Jacks with trapezoidal screws:

Screw:

NEFF Grease 2

Follow the QR-Code for Safety data sheet

Bevel gear:

Aral Degol GS220

Safety data sheet: www.neff-gewindetriebe.de



High Speed Screw Jacks with ball screws:

Screw:

NEFF Grease 2/3

Follow the QR-Code for Safety data sheet

Bevel gear:

Aral Degol GS220

Safety data sheet: www.neff-gewindetriebe.de



Fill quantities:

Type	G1	G2	G3
Fill quantities in liter:	0,15	0,5	3



In addition to our factory lubricants, other equivalent brand lubricants may also be used. This only applies if they are compared to the data sheets of the above manufacturers.



To much grease increases friction and therefore causes an increase in temperature.

7 Malfunctions



Service: Should malfunctions occur during operation, first try to identify the manner of the malfunction with the table below and to repair it. If it is a malfunction you can not repair, please contact our technical service (see last page).

Malfunction	Cause	Remedy
Unusual, constant running noises.	<ul style="list-style-type: none"> ➤ Rolling / grinding: Bearing damage ➤ Tapping: Irregularity in gearing 	<p>Check oil fill level. Consult the technical service.</p>
Unusual, irregular running noises.	Foreign object in the oil.	<p>Check oil fill level. Stop drive. Consult the technical service.</p>
Unusually high temperature at the housing.	<ul style="list-style-type: none"> ➤ Not enough oil. ➤ Defective gearing or bearing. 	<p>Check and correct oil filling. Consult the technical service.</p>
Grease or oil exists at the shaft seal ring.	Defective sealing.	Consult the technical service.
Oil exists at the shaft seal ring and at the screw.	Too much oil in the gear.	<p>Check and correct oli fill level. Consult the technical service.</p>
Trapezoidal screw quickly runs dry.	<p>Assembly fault: Impermissible lateral forces.</p>	<p>Repair assembly fault. Consult the technical service.</p>
The bevel gear shaft does not turn or the screw turns but does not move although the bevel gear shaft is turned.	The connection between the shaft and the hub or the gearing is broken.	Have the gear repaired.

8 Manufacturer's Declaration

We hereby declare that the following product:

High Speed Screw Jack
with trapezoidal screws or ball screws
model N, R or V
in the sizes
G1-G3
for lifting and lowering loads

was manufactured in accordance with the EC machinery directive 2006/42/EC annex II B on incomplete machinery.

This incomplete machinery must not be commissioned until the machine it is to be incorporated in has been declared to comply with the provisions of the EC machinery directive, the harmonized standards, European standards or the applicable national standards.

The manufacturer undertakes to forward the documentation on the incomplete machinery to national authorities on request. The technical documentation was created according to annex VII B.

Person responsible for documentation:

Andreas Ries, QA manager

Address of the person responsible for documentation:

Neff Gewindetriebe GmbH
Karl-Benz-Str. 24
71093 Weil im Schönbuch
Germany

The following harmonized standards have been applied:

DIN EN ISO 12100-1 Safety of machinery – Basic concepts, general principles for design, part 1:
Basic terminology, methodology

DIN EN ISO 12100-2 Safety of machinery – Basic concepts, general principles for design, part 2:
Technical principles and specifications

The following national standards, guidelines and specifications have been applied:

BGV D8 Accident prevention regulations for hoist gears, lifting and towing equipment

Neff Gewindetriebe GmbH
Karl-Benz-Str. 24
71093 Weil im Schönbuch
+49(0)7157/53890-0

